



**ALLANA BUICK & BERS**

Building solutions.  
Engineering for life.

# Plaza Deck Waterproofing Design Considerations

September 2012

Gerson S. Bers LEED-AP

# Copyright Materials

**This presentation is protected by US and International copyright laws. Reproduction, distribution, display and use of the presentation without written permission of the speaker is prohibited.**

**Allana Buick & Bers, Inc. 2012**



**ALLANA BUICK & BERS**

Building solutions. Engineering for life.



# Best Practice

Allana Buick & Bers, Inc. (ABBAE) is a Registered Provider with the American Institute of Architects Continuing Education Systems. Credit earned on completion of this program will be reported to CES Records for AIA members. Certificates of completion for non-AIA members are available on request.

This program is registered with the AIA/CES for continuing professional education. As such, it does not include content that may be deemed or construed to be an approval or endorsement by the AIA of any material of construction or any method or manner of handling, using, distributing, or dealing in any material or product. Questions related to specific materials, methods, and services will be addressed at the conclusion of this presentation.



# Gerson Bers, LEED AP – Principal

**EDUCATION:** B.S., Physical Sciences, University of Maryland

**CERTIFICATION:** LEED-AP: U.S. Green Building Council (USGBC);  
WUFI-ORNL Instructor: DOE - ORNL  
Certified Nuclear Gauge Operator  
AHERA Certified Project Manager

## **OVERVIEW:**

- Over 25 years experience providing technical consultation in building envelope technology.
- Principal consultant in design of waterproofing systems, exterior wall systems, roofing, below grade and other building envelope assemblies.
- Expert in sustainable building design, construction and rehabilitation, including LEED.
- US-DOE Trained and certified WUFI-ORNL Hygrothermal Building Envelope Simulation instructor.
- Completed numerous new construction, addition, rehabilitation, remodel and modernization projects for public and private sector clients.

## **BELOW GRADE WATERPROOFING EXPERIENCE:**

- New Stanford Hospital, Palo Alto, CA
- University of Chicago, New Hospital Pavilion, Chicago, IL
- San Diego International Airport, San Diego, CA
- New US Embassy, The Hague, Netherlands,
- New Civic Center and City Hall, Newport Beach, California



# Plaza Deck Waterproofing Agenda

- **Plaza Deck Configurations**
- **Structural Considerations**
- **Waterproofing Membranes**
- **Drainage**
- **Protection and Root Barriers**
- **Insulation**
- **Warranties**
- **Questions**



## Plaza from Latin *Platea* “Street or Courtyard”



***“Exposed pedestrian surfaces constructed over occupied spaces.”***



# Plaza Decks

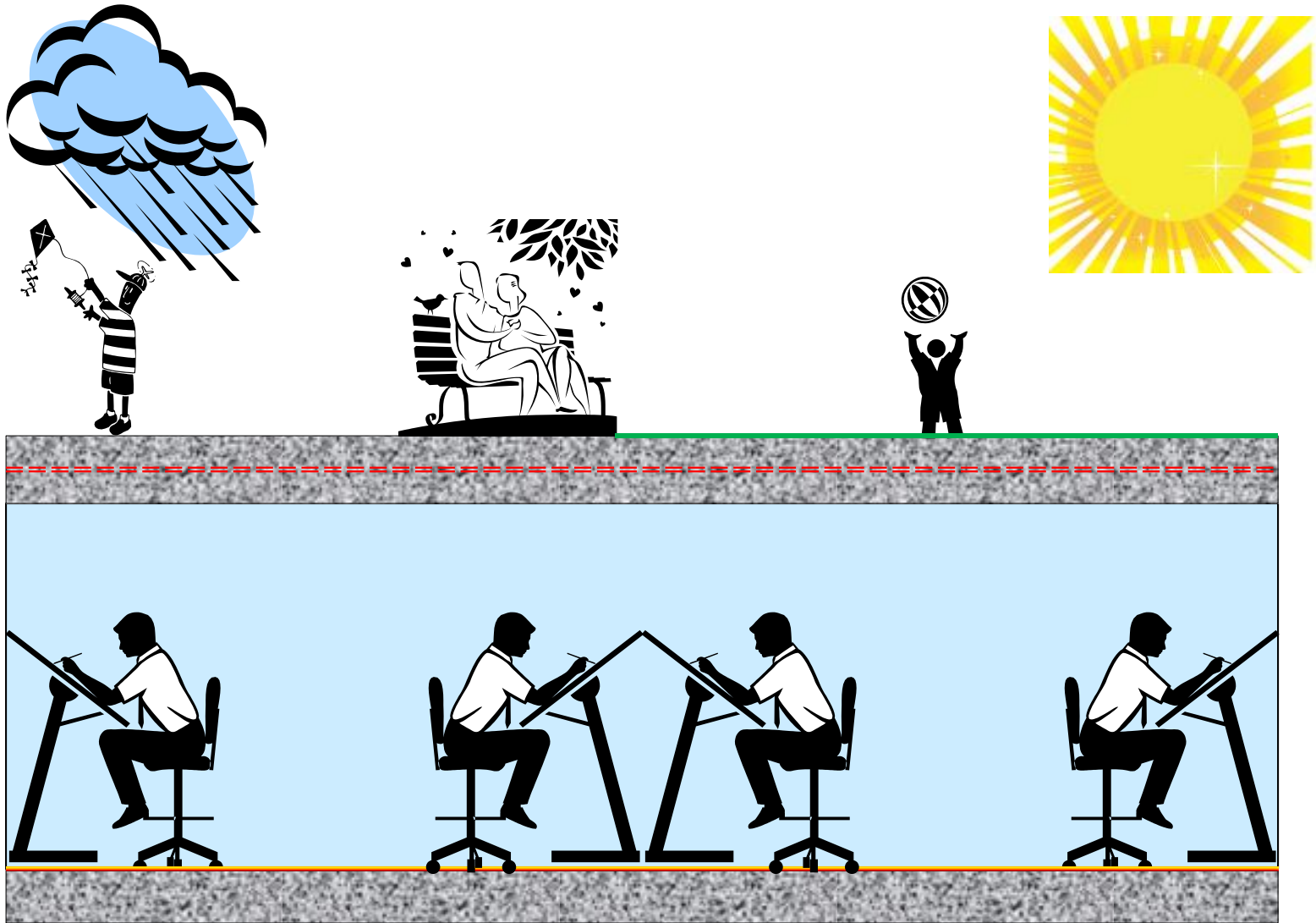



# Plaza Decks



# Plaza Decks



# Plaza Decks



# Plaza Decks



# Structural Substrates



# Structural Substrates

- A plaza deck is a roof
- Typical structural decks we see:
  - Wood
  - Steel
  - Concrete



# Wood Structural Decks

- **Difficult to accommodate heavy deck loads**
- **May require gypsum layer for fire resistance**
- **Restricted to lighter residential decks**
- **Fewer waterproofing system options**



# Steel Structural Decks

- **Requires mechanical attachment of a rigid overlay to receive waterproofing**
- **More difficult to attain required capacity without using deep structural members**
- **Fewer waterproofing system options**
- **Not frequently seen in plaza deck construction ...unless...concrete filled.**





# Concrete Structural Decks

- **Readily capable of heavy deck loads**
- **Structural or placed in vented steel decks**
- **Normal or lightweight structural types available**
- **Largest number of waterproofing options**
- **Obtain slope using finished concrete surface**
- **Typically the best substrate**



# Waterproofing Deck Slope

- **Waterproofing is less likely to leak if you there is no standing water**
- **2007 IBC Code: Section 1507**
  - All noted low slope roof systems must have minimum 2% slope (1/4"/foot)
- **Despite marketing...plaza decks are roof assemblies**



# Waterproofing Deck Slope

- **Slope best achieved in structural deck**
  - Permanent feature of building
  - Roofer not responsible for adding slope
- **Concrete deck easiest to achieve slope**
  - Slope can be cast into deck surface
  - Easier to resolve slopes for complex area geometry
- **Don't forget drain location layout**



## General Plaza Deck Types



# General Plaza Deck Types

- Protected Membrane
- Split Slab
- Traffic Bearing
- Surface Applied
- Roof Garden



# Protected Membrane (IRMA)

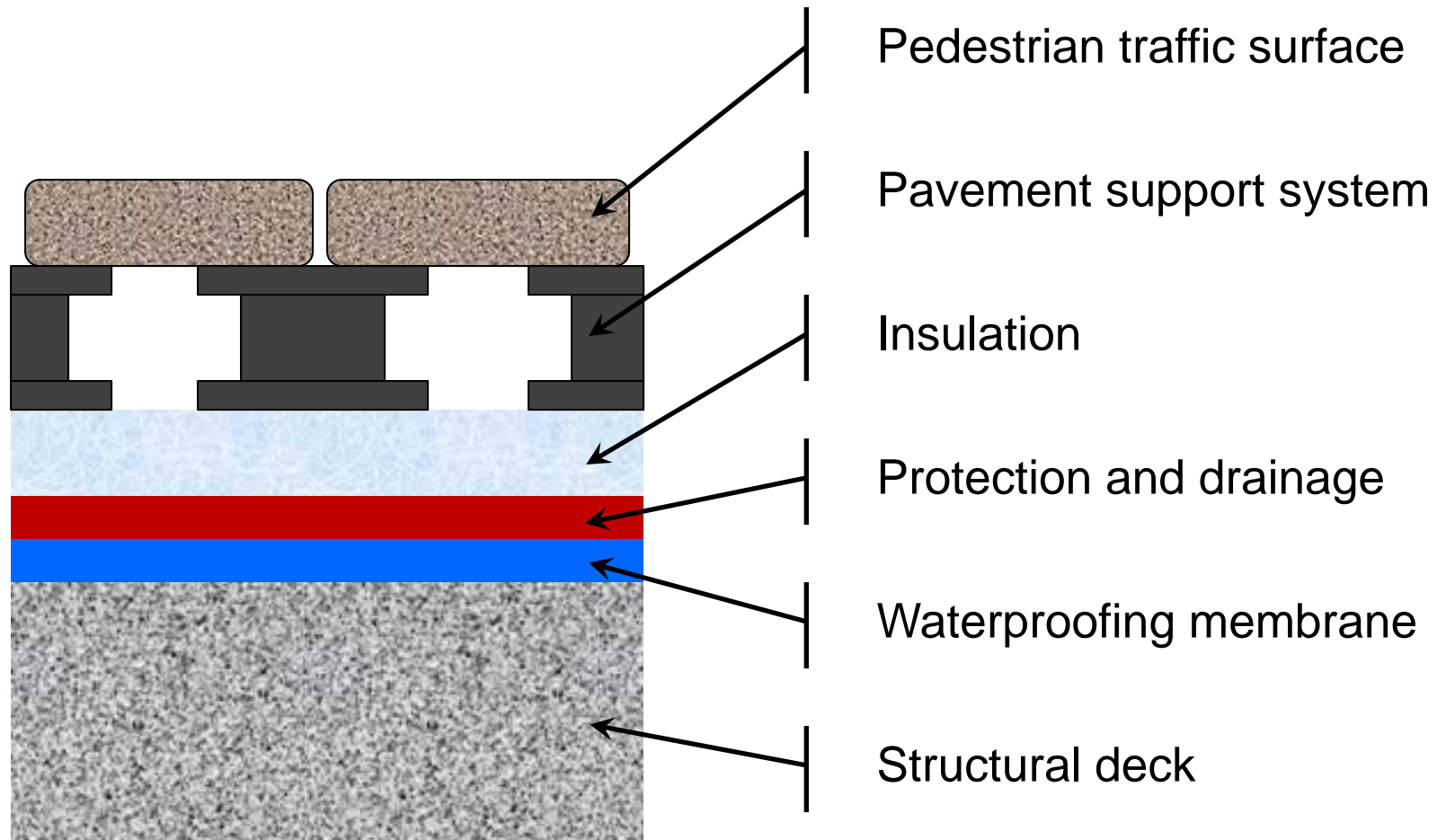

# Split Slab

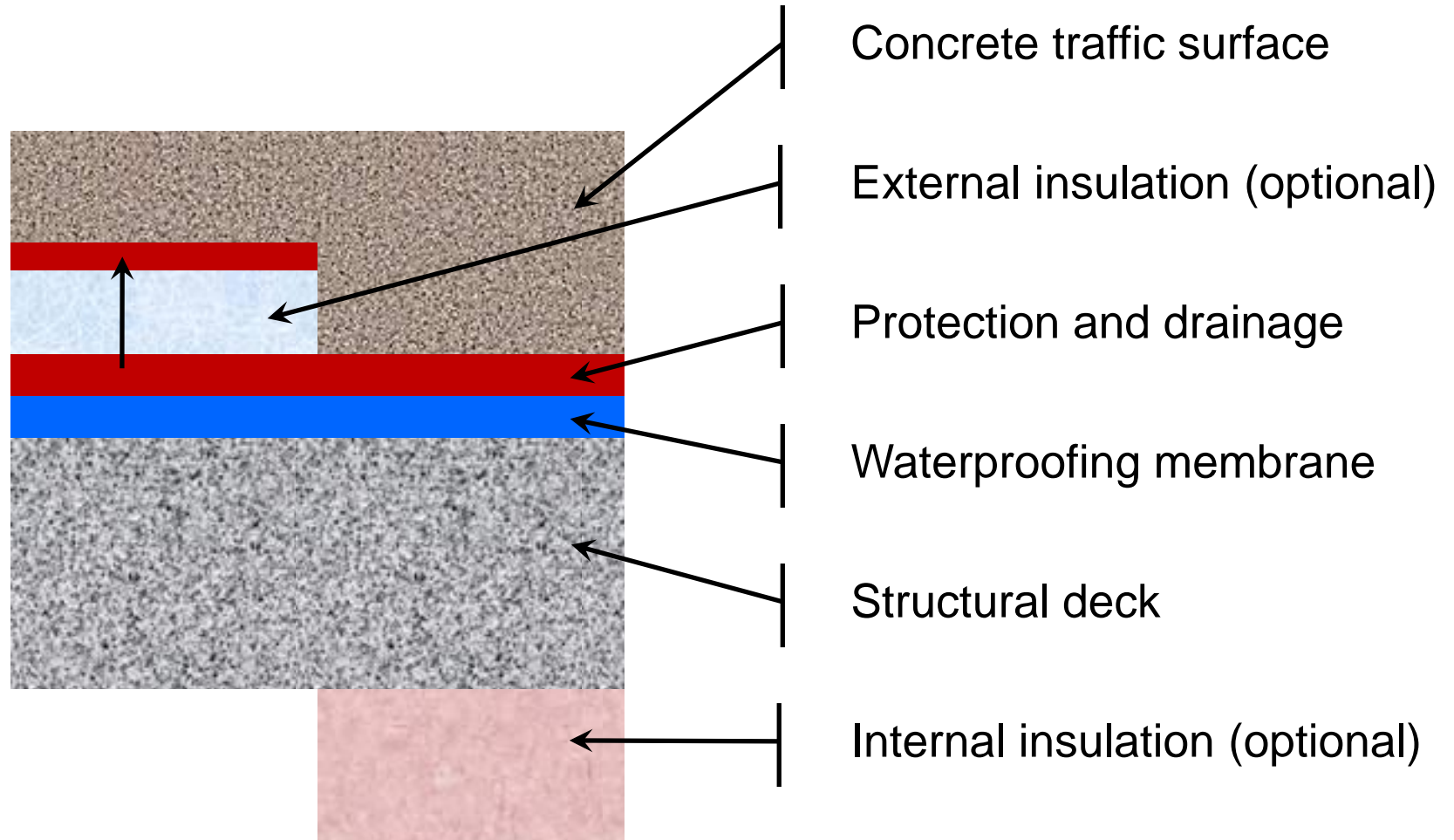

# Surface Applied

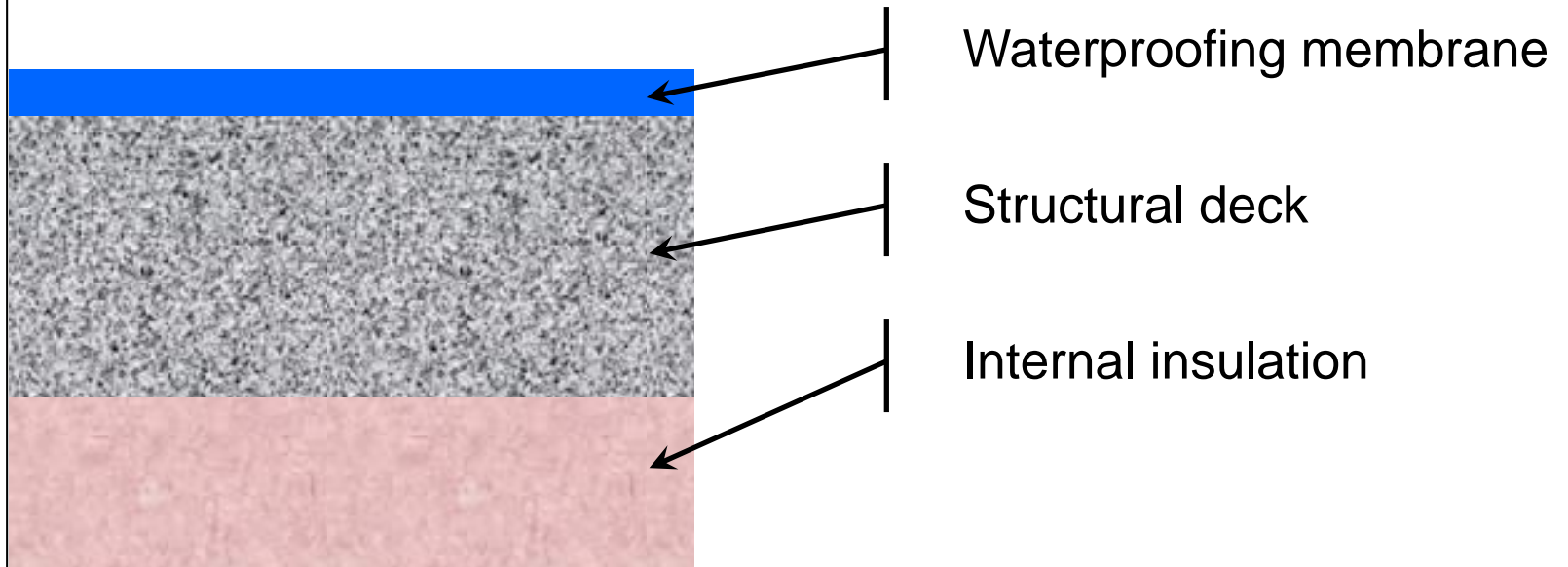



# Roof Gardens

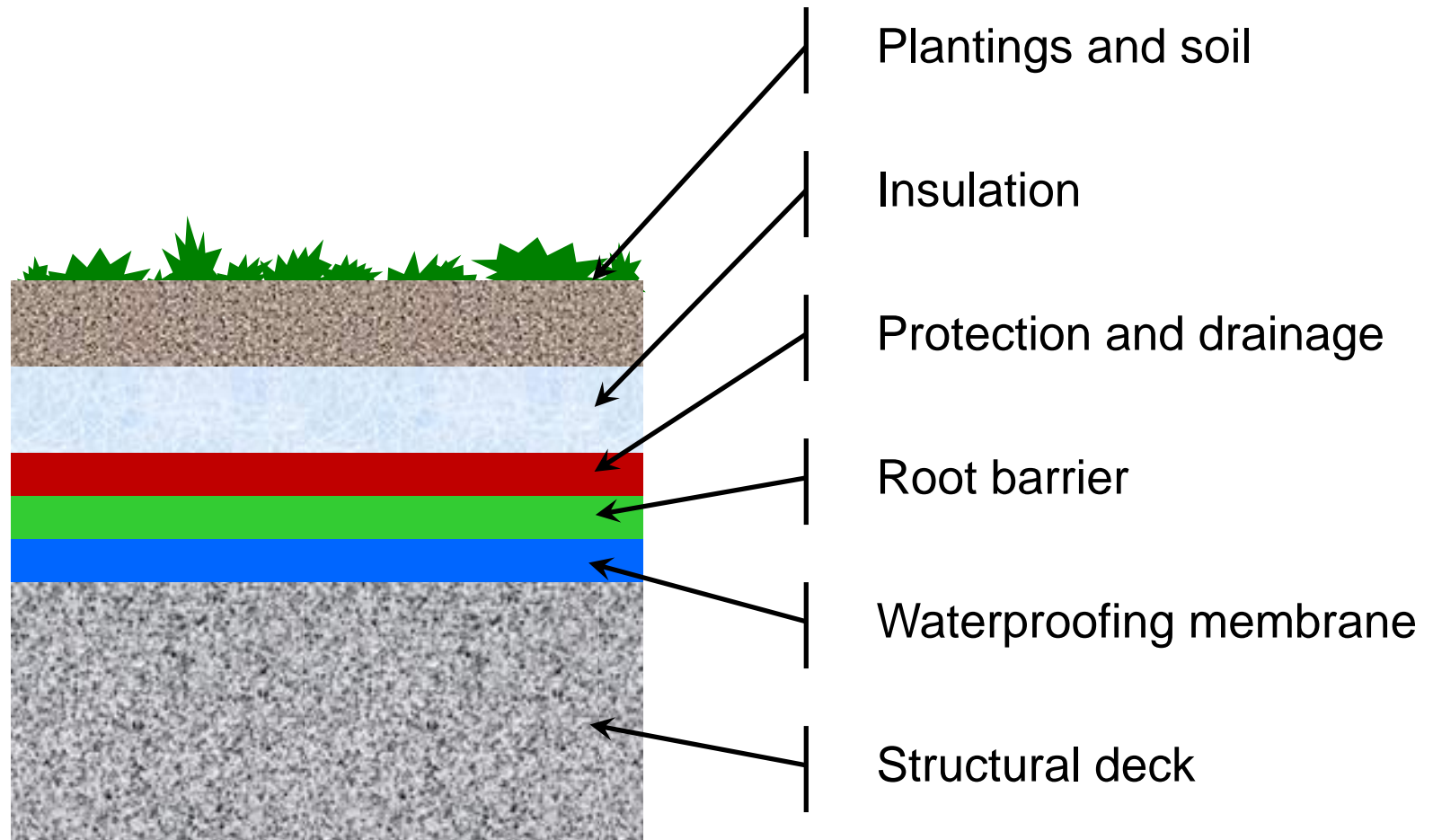

# Waterproofing Membranes

- **Adhered Systems**
  - Bonded to substrate
  - Hole in membrane may not result in leaks
- **Non-Adhered Systems**
  - Floats over substrate
  - Leaks may appear far from membrane hole
- **Composite Membrane**
  - Secondary system to prevent migration



# Adhered Membranes

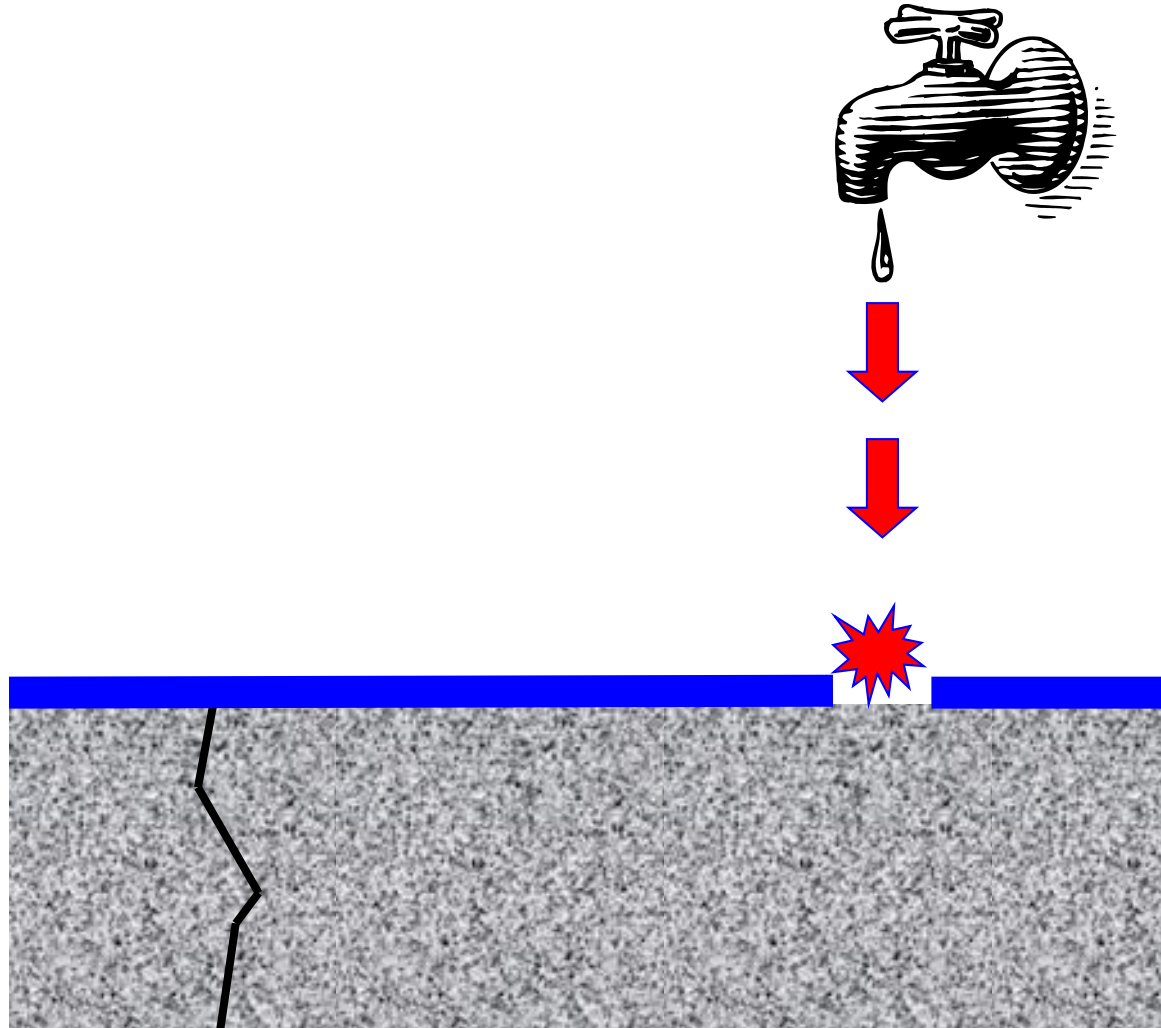

# Non-Adhered Membranes

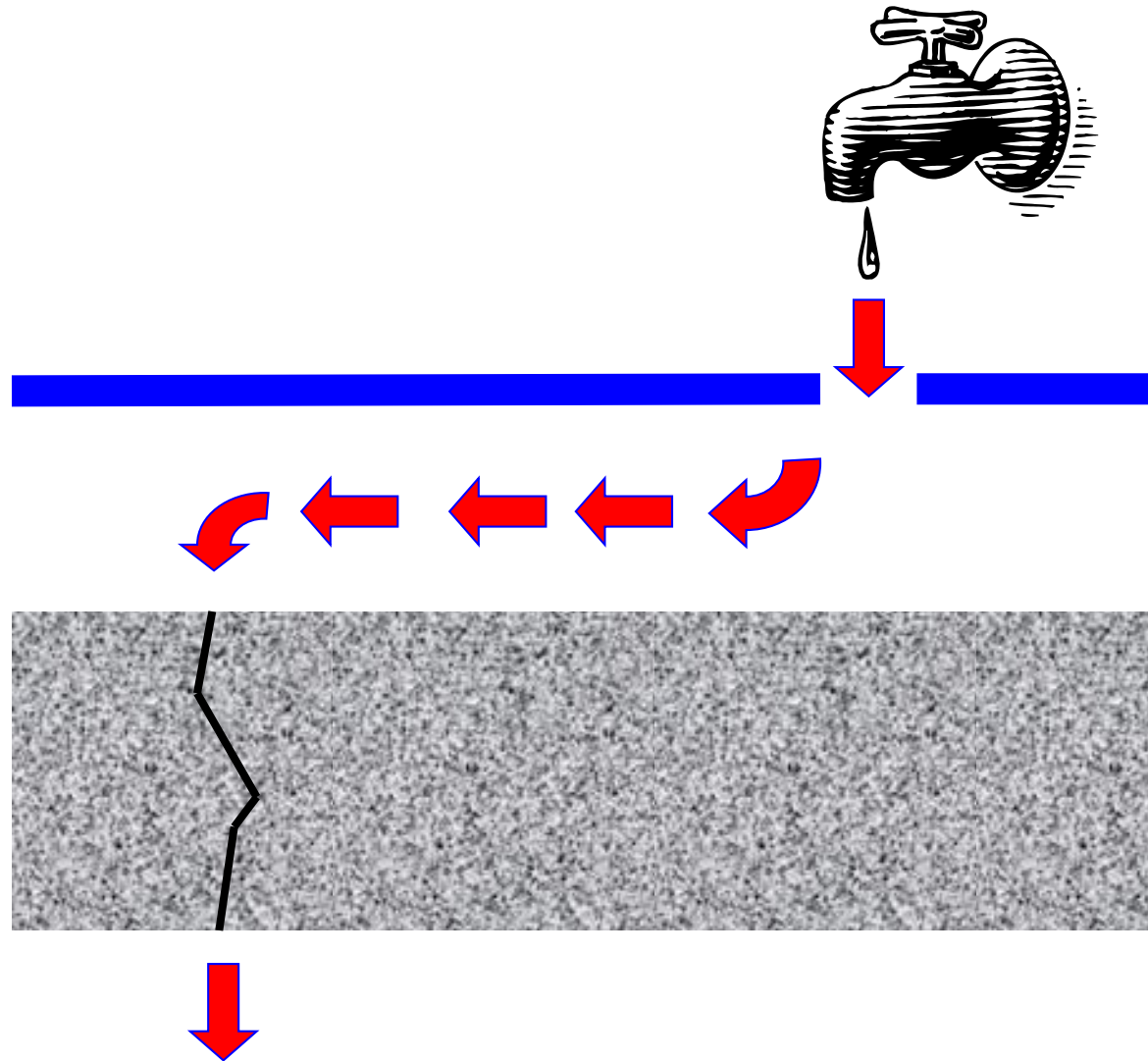

# Composite Membranes

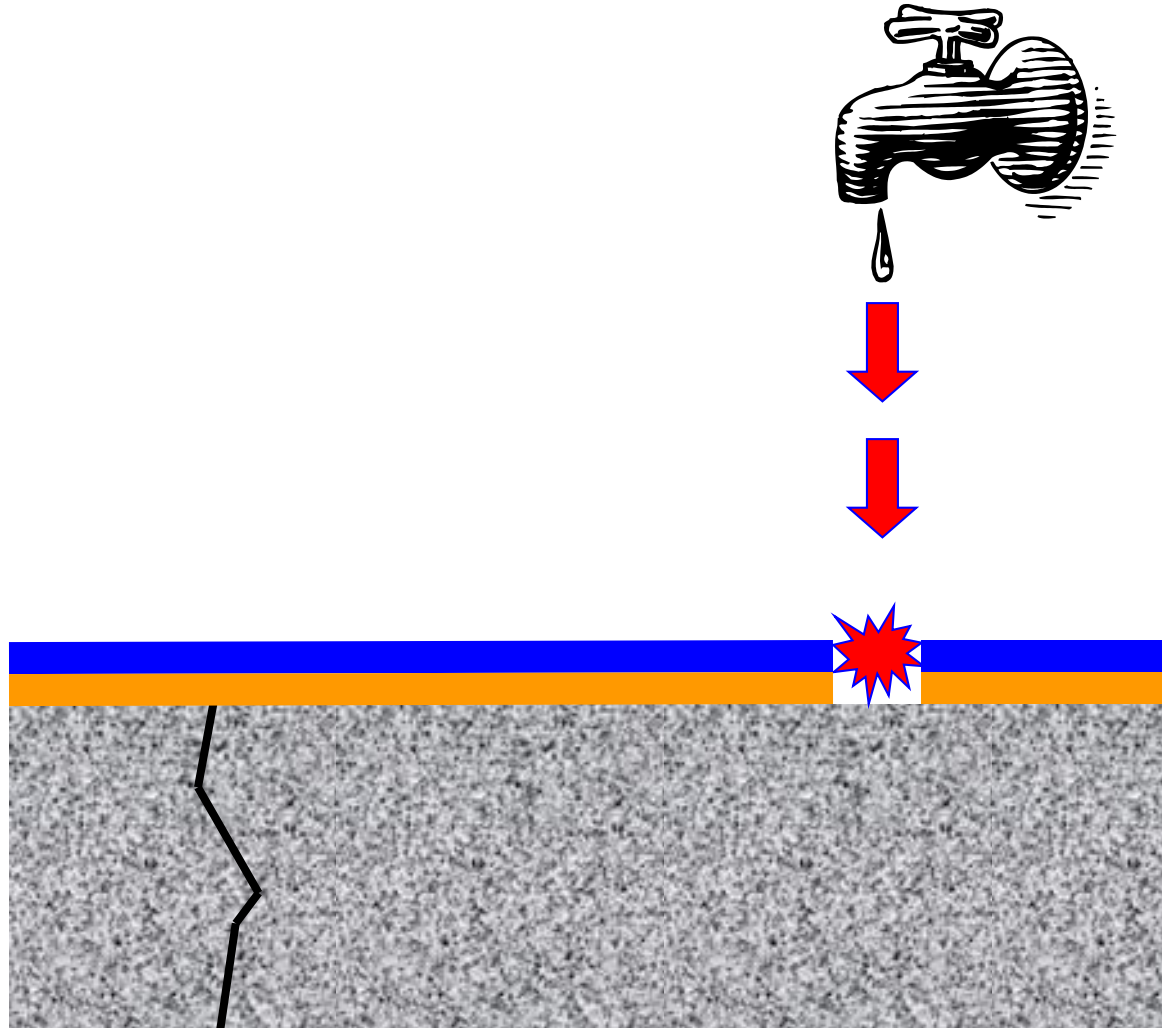

## Common Membrane Systems



- **Fluid Applied Systems**
  - Hot Applied
  - Cold Applied
- **Membrane Systems**
  - Thermoset (*Rubber*)
  - Thermoplastic (*Plastic*)
  - Reinforced SBS modified asphalt sheets
  - Self Adhering (*Peel and Stick*)



- **Hot Systems**
  - **Rubberized Asphalt (HRA)**
    - For split slab & protected systems
    - Typically reinforced with polyester
    - More that 30 years of experience
    - Must be protected from exposure
    - Installation is reasonably forgiving





# Plaza Decks



# Plaza Decks



# Plaza Decks



# Plaza Decks



- **Cold Systems**

- **Urethane**

- Split slab, protected membrane or exposed
    - Either reinforced or non-reinforced
    - Cure times typically more than 24 hours

- **PMMA (*poly-methyl-methacrylate*)**

- Typically an exposed membrane
    - Hard & durable rubber like surface
    - Cures very quickly (<2hrs)



- **Cold Systems**

- Polyester

- Typically exposed membranes
    - Reinforced with polyester scrims
    - Moderately fast cures (<24 hrs.)
    - Very sensitive to high/low temperature installation

- Acrylic

- Typically an exposed membrane
    - Systems are composites of cement and other polymers



## Beware Osmotic Blistering

- Primarily Urethane/Polyurethane over concrete
- Membranes may be permeable
- Permeable membranes can induce osmotic cells
- Can be avoided by using VERY low perm rate membranes  $0.00 < 0.002$  perms



## Beware Osmotic Blistering

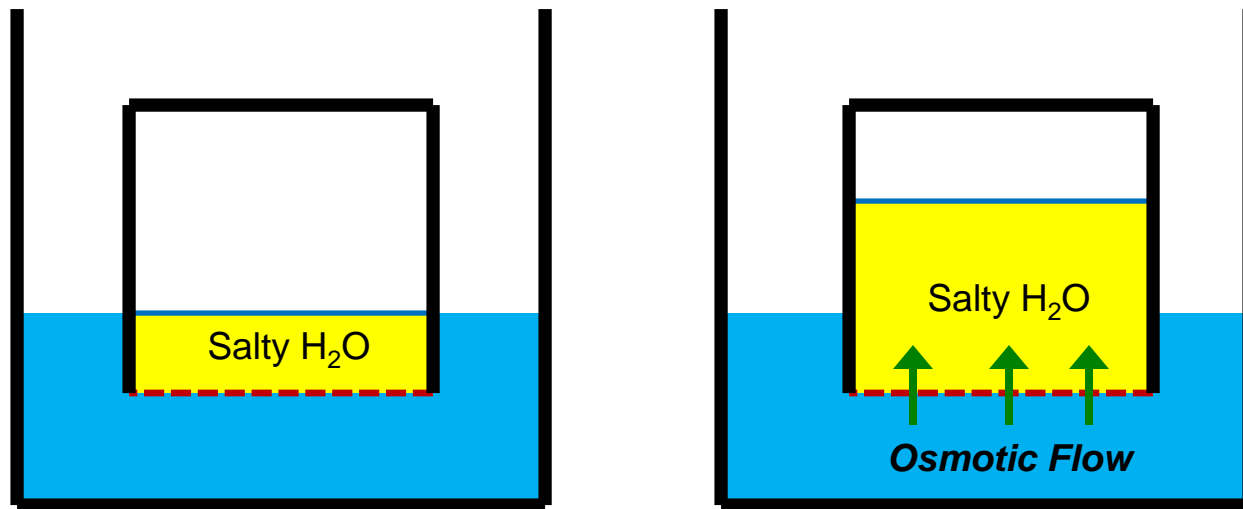



## Beware Osmotic Blistering

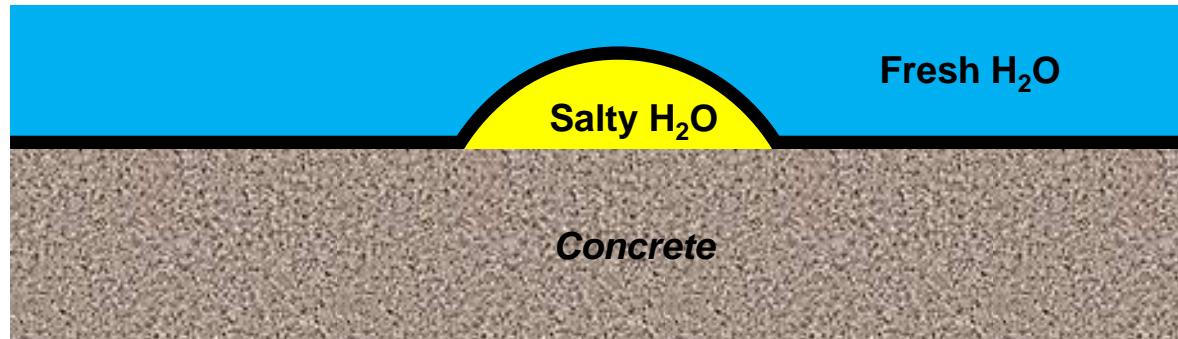

# Plaza Decks



# Plaza Decks



# Plaza Decks



# Plaza Decks



# Plaza Decks – Traffic Bearing



# Plaza Decks – Traffic Bearing



- **Adhered Membranes**

- **SBS Modified Asphalt/Polyethelene Sheets**

- Split slab or protected membrane systems
    - Known as “Peel and Stick” membranes
    - Membrane laps are weak point in system

- **SBS Modified Asphalt Sheets**

- Split slab or protected membrane systems
    - Systems can be applied two ways:
      - Hot (torch or hot air)
      - Cold adhesive





# Plaza Decks



# Plaza Decks



# Plaza Decks



# Plaza Decks



# Plaza Decks



# Plaza Decks



- **Non-Adhered Membranes**
  - **Thermoplastic Sheets**
    - Typically reinforced PVC or PVC alloy
    - Factory manufactured - field assembled
    - Seams are heat fused
    - If seaming is well done, great longevity
    - Installed as a “loose laid” or “grid system”
    - \* Self-adhering sheets new to market



# Loose Laid Sheet Membrane

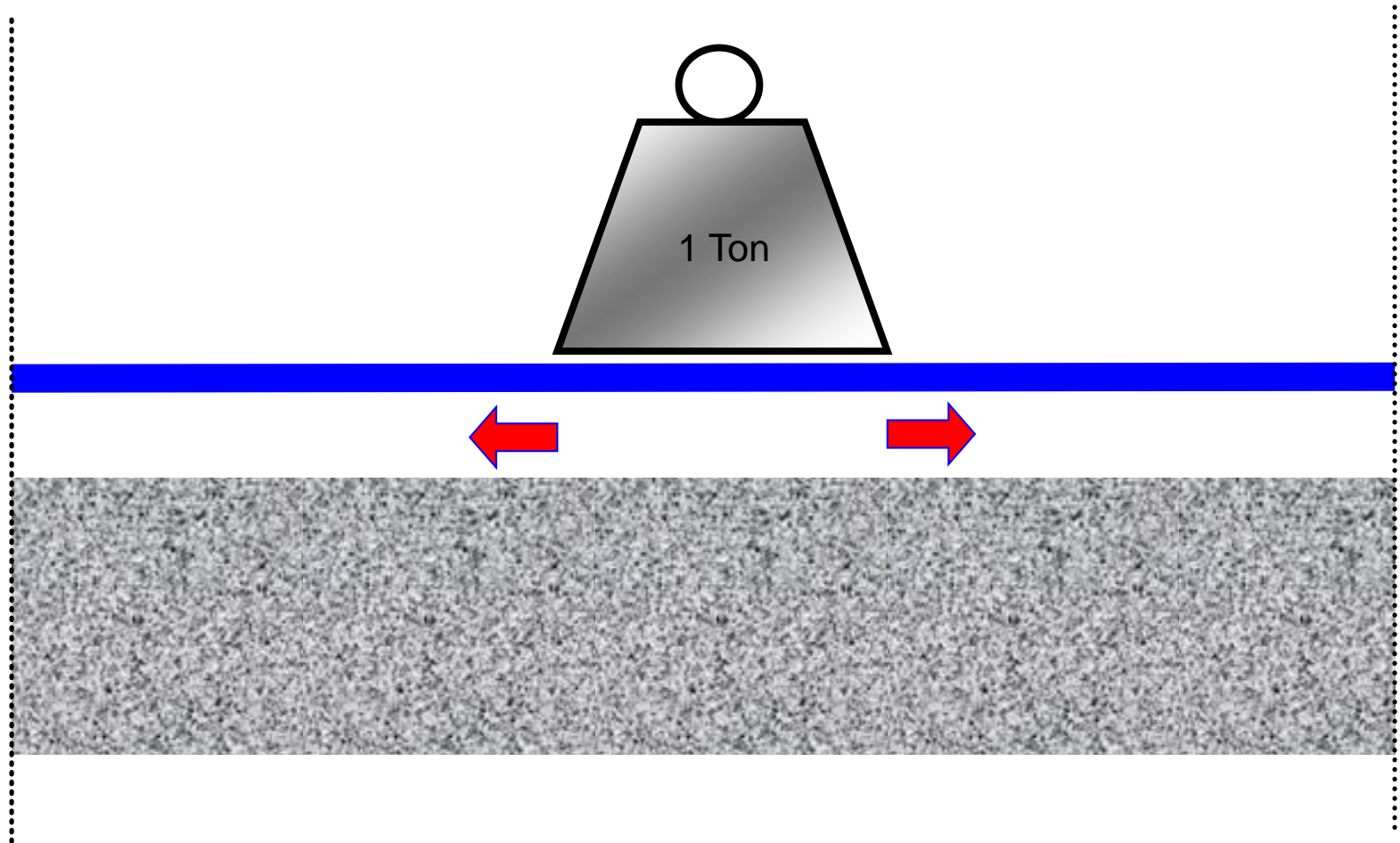



# “Grid” Sheet Membrane

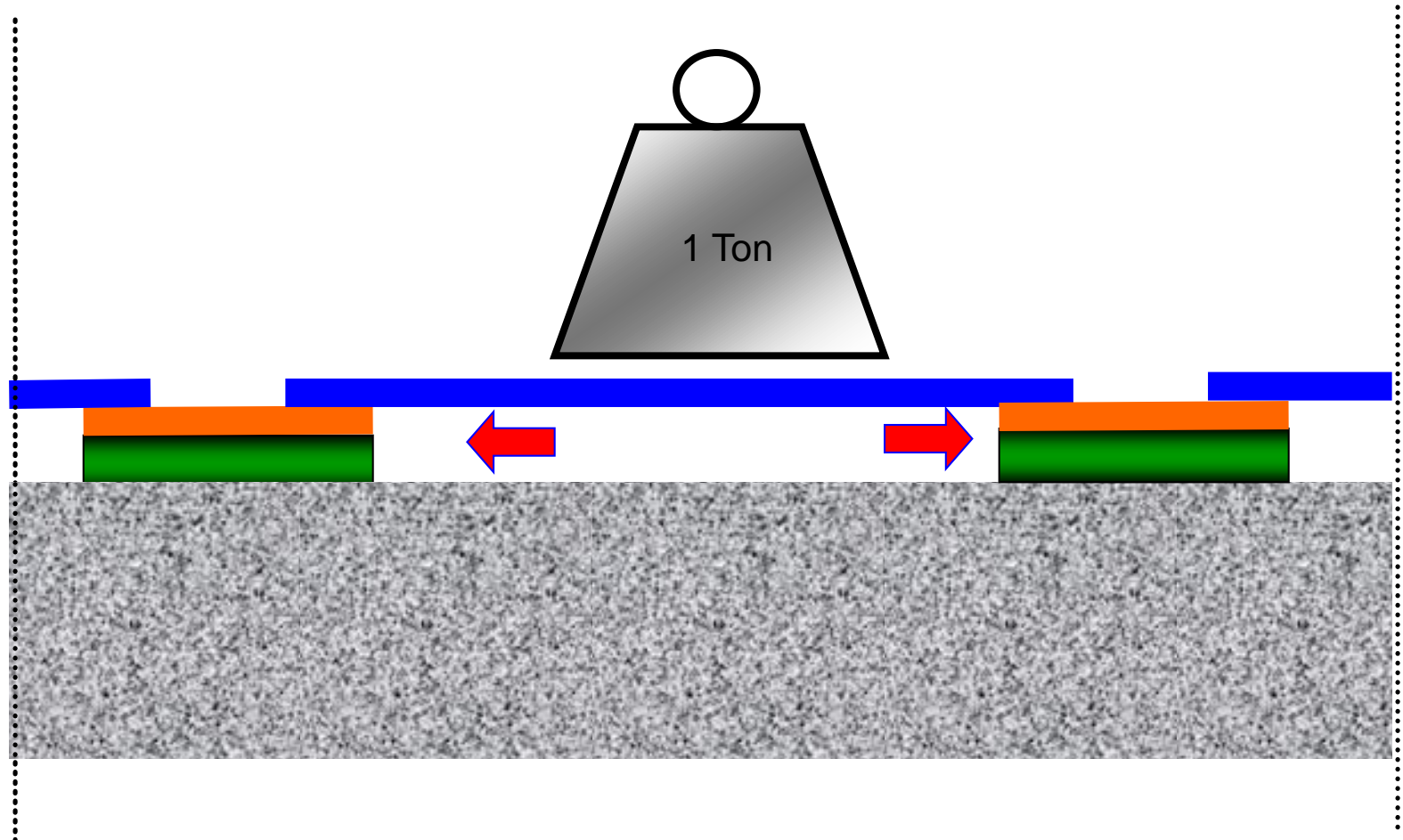

# “Grid” Sheet Membrane

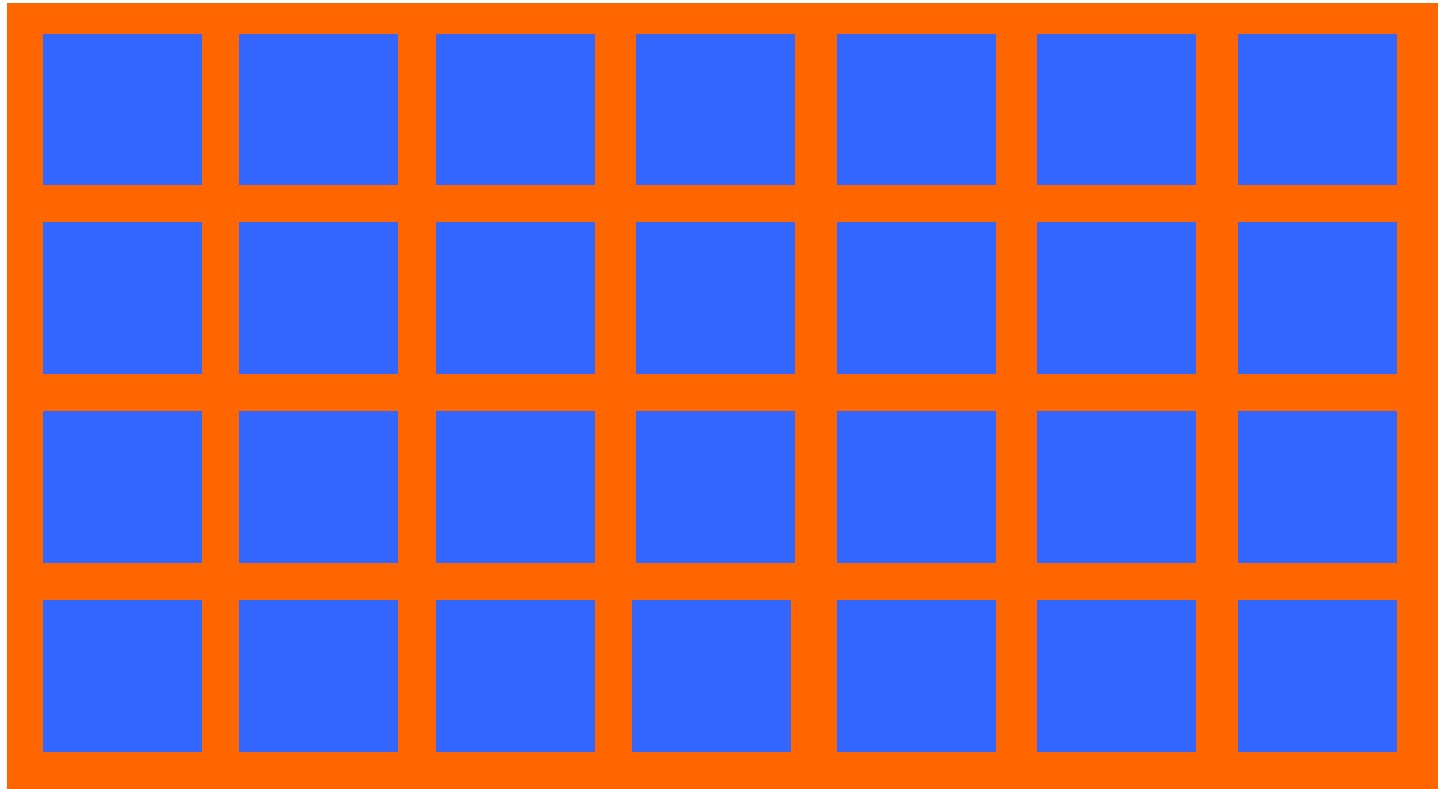

**Grids laid out in logical pattern to limit leak travel location to a single cell**



# Plaza Decks



# Plaza Decks



# Plaza Decks



# Plaza Decks



# Plaza Decks



# Plaza Decks





# Plaza Decks



# Plaza Decks



- **Non-Adhered Membranes**
  - **Thermoset Sheets**
    - Butyl or EPDM rubber sheets
    - Factory manufactured - field assembled
    - Seams are spliced with an adhesive
    - Typically loose laid...but a few are adhered
    - Not many constructed these days



# Plaza Drains

- **Top mounted inlet**
- **Secondary inlet at membrane level**
- **Body/extension often has openings**
- **Height is typically adjustable**



## Plaza Deck Drainage



# Drainage Layers

- **Placed above the waterproofing layer**
  - Conducts water to drain sites
  - In conjunction with roof slope, prevents standing water in plaza system
  - Can also provide mechanical protection to the waterproofing membrane
- **Plastic cores with filter fabric covering**
  - High compressive strength
  - Filter fabric prevents fines from clogging drain path
  - Carefully select to match waterproofing system



# Plaza Deck Drains

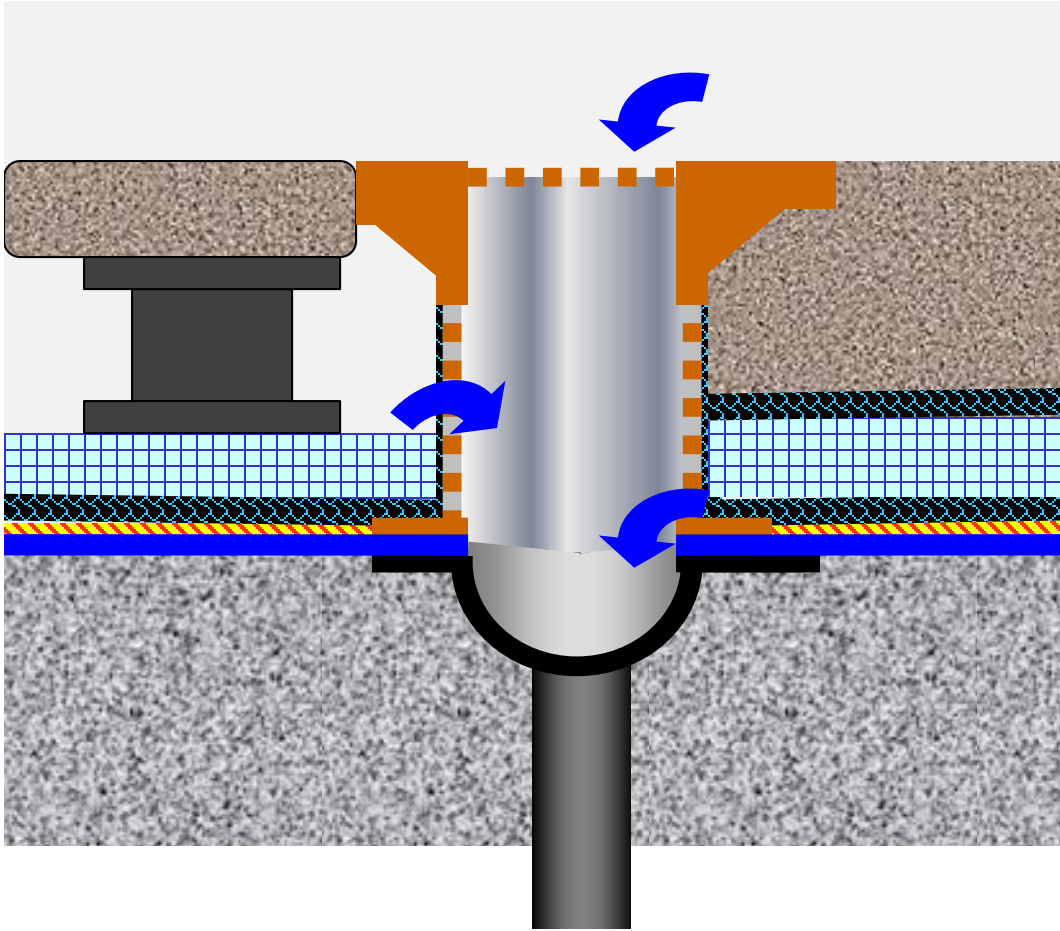

## Protection Layers





# Protection Layers

- **All split slab and protected membranes require a protection system**
  - **Fluid Applied Systems**
    - Rolled protection mats or cap sheets
    - Hard asphalt/mineral planks/panels
    - Recycled rubber sheets
  - **Sheet Applied Membranes**
    - Plastic protection sheets (PVC or HDPE)
    - Drain panels can be used as part of the protection system
  - **Pick Carefully...**



# Plaza Decks



# Plaza Decks



# PLAZA DECKS



## Insulation Layers



# Insulation Layers

- **Two preferred locations**
  - Over the waterproofing membrane
  - Under the structural deck
  - Avoid placing between waterproofing and structural roof deck
- **Exposed plaza deck insulation**
  - High compressive strength
  - Closed cell so that it will not absorb water
    - Extruded polystyrene foam (popular)
    - Foamed glass (rare)



# Plaza Insulation Types

- **Must be closed cell**
- **Extruded polystyrene**
  - High compressive strength (20 to 100 psi)
  - Must be protected from the sun
  - R=5.0/in
- **Foam glass**
  - High compressive strength (90 psi)
  - Very dimensionally stable
  - > 1,800°F melting point
  - R=3.44/in



# Plaza Decks





# Insulation Under Roof Deck

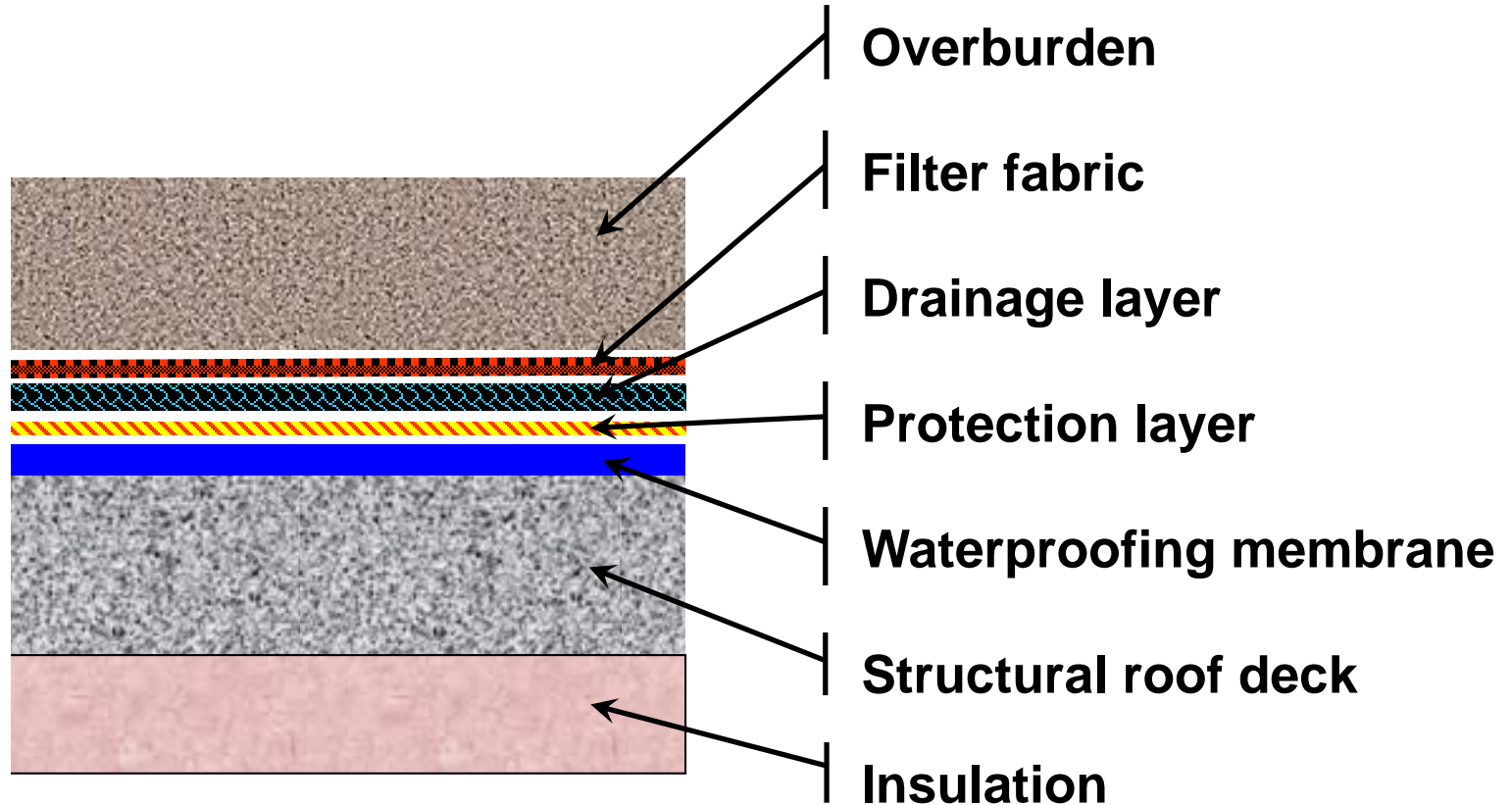

**Insulation is independent of waterproofing and plaza**



# Insulation Above Waterproofing

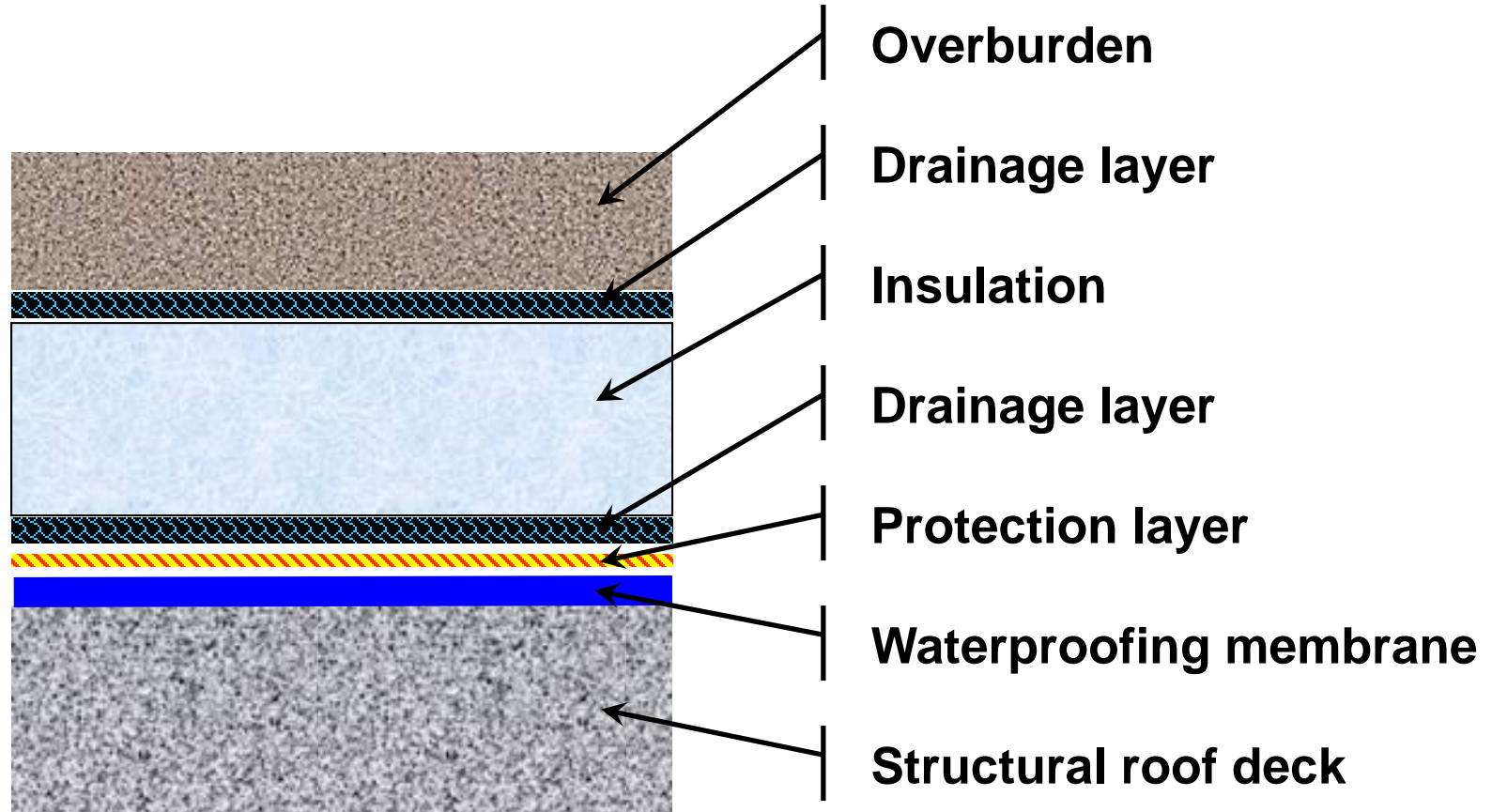

Insulation must have sufficient compressive strength (60 to 100) psi and must not absorb water



# Insulation Below Waterproofing

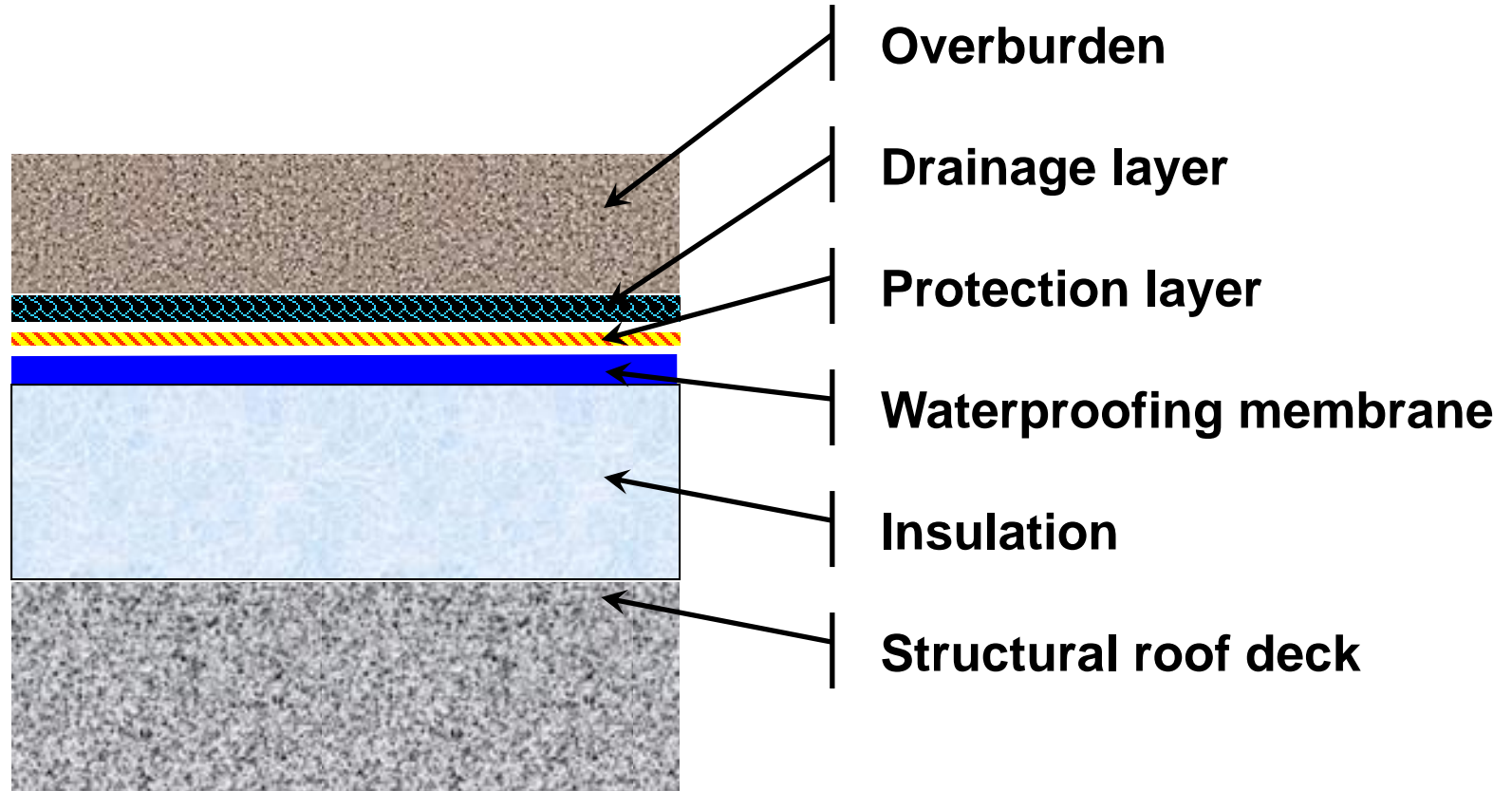

***VERY BAD IDEA***



***A warranty never  
prevented a plaza deck  
from leaking.***



***Great waterproofing systems poorly installed will perform no better than a fair system perfectly installed.***



***Obtain independent full-time construction observation for concealed waterproofing systems.***



***Require the contractor to provide Electronic Field Vector Mapping (EFVM) prior to flood testing.***



***Require flood testing to confirm performance prior to concealment.***





***Before specifying a warranty make certain the waterproofing system has performed for an equivalent period of time.***



***Specify warranties that include all system components including overburden.***



# Thank You!

## Gerson S. Bers

[gbers@abbae.com](mailto:gbers@abbae.com)

